

**GENERAL PURPOSE
SURVEY METER**

Model 491

TABLE OF CONTENTS

<u>Topic</u>	<u>Title</u>	<u>Page</u>
1	INTRODUCTION	1
2	SPECIFICATIONS	3
3	OPERATION.	5
4	CIRCUIT DESCRIPTION.	15
5	CALIBRATION.	17
6	MAINTENANCE.	22
7	REPLACEABLE PARTS.	24

<u>Figure</u>	<u>Title</u>	<u>Page</u>
1	Model 491 Survey Meter	7
2	Corrections to be Made to Readings with Various Switch Positions	8
3	Model 489-4, 489-35 Probe Energy Response	13
4	Model 491-30, 491-40 Probe Energy Response	14
5	Schematic Circuit Diagram.	18
6	Probes	19
7	Circuit Board Assembly	23

<u>Table</u>	<u>Title</u>	<u>Page</u>
I	Background Count, Statistical Error. . .	10
II	Detector Probes.	12
III	Probes Available for Use with Survey Meter 491.	21

1 INTRODUCTION - The Model 491 Wide Range Geiger-Mueller (GM) Survey Meter is a sensitive pulse count ratemeter and power supply to be used with a variety of GM probe assemblies for alpha, beta and gamma detection. Extensive use of solid state circuitry makes the Model 491 a reliable and rugged instrument. Four D-cell batteries provide over 100 hours operational life when used for four hours per day.

1.1 Physical Description - The die cast aluminum case top and drawn steel case bottom are fastened with two pull catches for closure. The visual readout for the instrument is a military type, waterproof, 3 1/2 inch meter. Aural indication of count rate is available from a phone connector for either an external speaker or earphones.

The instrument controls consist of a range selector switch which has an off position, a battery check position, and seven overlapping range positions; and a three position response switch which adjusts the time constant of the meter.

The GM detectors are connected using a waterproof, high voltage, coaxial connector and coiled cable. They are mounted to a convenient clamp on the handle post. A low intensity beta check source verifies the operational status of the 491. The batteries are retained in an impact resistant plastic battery box which cannot be corroded by leaking battery fluids. Battery contacts are readily replaceable without tools to facilitate cleaning or replacement.

High sensitivity is achieved in the Model 491 through use of seven overlapping linear ranges from 150 to 150,000 cpm full scale which correspond to 0.1 to 100 mR/h when using the 491-30 Probe Assembly. An accuracy of $\pm 10\%$ on all ranges can be obtained with tracking (agreement of readings) between ranges of better than $\pm 5\%$ of full scale. High voltage adjustment is also precluded through the use of highly stable VICTOREEL high voltage regulating diodes.

2 SPECIFICATIONS

1. Range - 0 to 0.1, 0 to 0.3 through 0 to 100 mR/h in seven linear ranges. Corresponds to 150, 450 to 150,000 cpm when used with Probe 491-30, calibrated with ^{137}Cs .
2. Accuracy - $\pm 10\%$ of full scale on all ranges with agreement ranges better than $\pm 5\%$ of full scale when calibrated with ^{137}Cs .
3. Time Response - 12, 5, 0.8 seconds
4. Temperature Range - -40°F to 125°F (-40°C to 51°C) excluding batteries. Alkaline batteries are recommended at temperatures below 32°F (0°C).
5. Battery Complement - Four D-cells, NEDA type 13
6. Battery Life - 100 hours at four hours/day
7. Controls - Nine position range selector switch; three position response selector switch
8. Energy Dependence - Dependent on the probe type used. See the energy response curves included in the manual.
9. Output Connector - MHV type, IPC 27000 (UG931/U) mounted on case top.
10. Construction - Splash-proof, shock-proof, two piece, all metal case
11. Supplied - Check source on the side of the case

2 SPECIFICATIONS (Cont'd)

12. Dimensions (H x W x L) - 7 in. x 4 1/2 in. x 8 3/4 in. (Height includes handle) (17.8 cm x 11.4 cm x 22.2 cm)
13. Net Weight - 5 lbs (2.3 kg)
14. Shipping Weight and Volume - 8 lbs (3.6 kg); 1.5 cu. ft.

3 OPERATION

3.1 Installation - The instrument is shipped with batteries installed. No installation is necessary.

3.2 Batteries - Snap open the pull catches at each end of the case and remove the case bottom. This will expose the circuit board assembly and the battery compartment.

Squeeze the battery retainer clamp to remove it from the compartment. Install D-size flashlight cells in the openings provided, observing the proper polarity. Replace the retained clamp and the case bottom.

If operation below 32°F is contemplated, use alkaline batteries. Remove all batteries if the instrument is to be stored for an extended period of time.

3.3 Detector Connection - Turn the instrument off and insert the probe connector on the probe cable into the coaxial receptacle to the right of the handle post. Press down, turn clockwise for about 1/4 turn and then release to lock the bayonet catches on their mating connector pins.

3.4 Meter Readings - The meter scale is calibrated in milliroentgens per hour (mR/h) when used with the standard model 491-30 Probe on ^{137}Cs gamma radiation. The secondary scale on the meter face indicates approximate counts per minute (cpm). Multiply the scale reading by the range switch setting (X100, X30, etc.) to determine the dose rate. These corrections are illustrated in Figure 2.

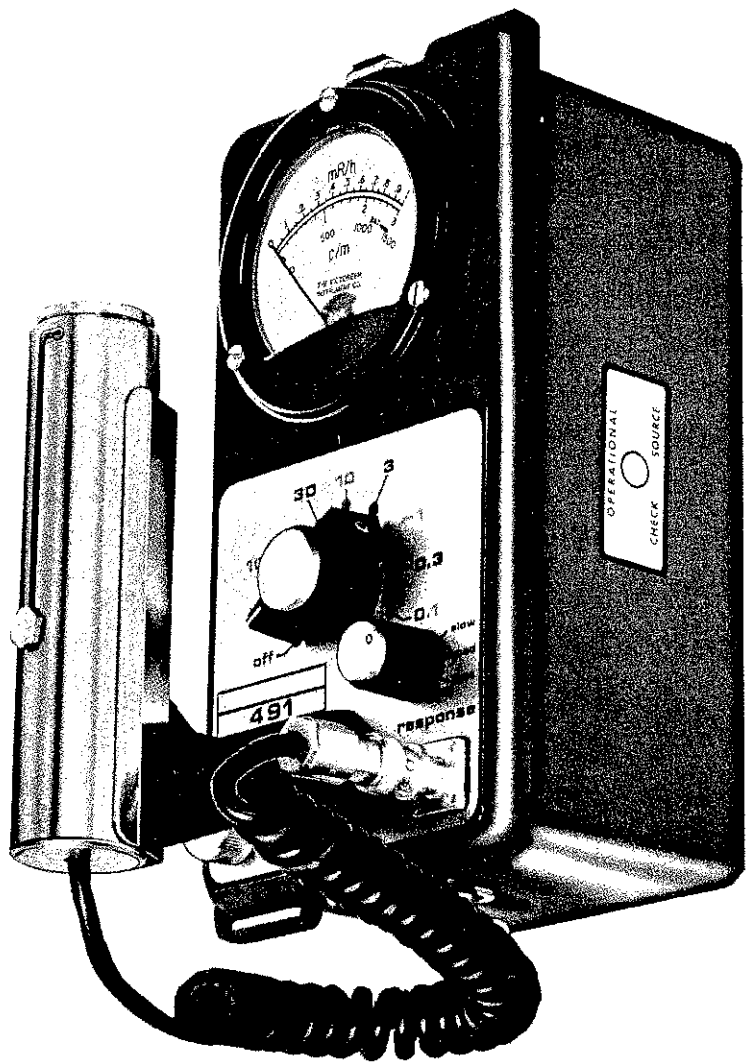
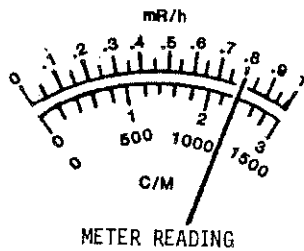

Figure 1. Model 491 Survey Meter

METER, RANGE SWITCH CORRELATION TABLE

FUNC. SW. POSITION		FULL SCALE INDICATION (mR/h)	
RED	BLACK	RED SC.	TOP BLACK SC.
100		100	
	30		30
10		10	
	3		3
1		1	
	0.3		0.3
0.1		0.1	

INTERPRETATION OF METER READING
(USING THE STANDARD MODEL 491-30 PROBE)



EXAMPLE:

$$\begin{array}{r} .8 \text{ READING ON TOP RED SCALE} \\ \times 10 \text{ RANGE} \\ \hline 8.0 \text{ mR/h (Approx. 12000 C/M)} \end{array}$$

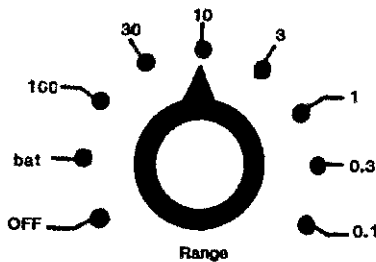

Figure 2. Corrections to be Made to Readings with Various Switch Positions to Give True Reading of Radiation

It is the nature of all radiation detectors that they respond differently to different radiation energies. Energy response is not to be confused with dose rate response. If the radiation being measured is other than ^{137}Cs gammas, or if the probe being used is not the Model 491-30, appropriate standardization factors for the mR/h scale (not the cpm scale) are required. Energy response curves for the VICTOREEN GM detector probes are shown in Figures 3 and 4. Divide the meter reading by the ratio of indicated-to-true dose rate for the particular probe and energy to determine the true dose rate.

The slower response mode averages statistical fluctuations so that a more accurate reading may be obtained.

3.5 Use of Headphone or Speaker - If the operator chooses to use a headphone or speaker with the instrument, the one used is screwed into the connector provided immediately to the left of the handle post. The operator will note that each pulse arriving at the instrument is indicated by a distinctly audible "click" in the headphone or speaker. These clicks or pulses, as they are produced from a radiation detector probe, are randomly spaced in time so that one may wait for several seconds before any click is observed, and then there may be two or three in rapid succession.

Accurate measurements of background and other low level radiation can be made by counting clicks and timing them with a watch which has a second-hand. The procedure is to count a given number of counts and observe the time required to obtain these counts. The radiation rate in counts per minute is the number of counts divided by the time in minutes.

Table I gives the number of counts that are required to provide a given percentage error, where standard error is defined as that error for which, in 68 cases out of 100, the true error will not exceed the given percentage error. The nine-tenths error is that error for which the true reading is not different from the observed reading within the given percentage limits for 90 cases out of 100.

TABLE I: BACKGROUND COUNT, STATISTICAL ERROR

Percent Error	Number of Counts Required For:	
	Standard Error	Tenths Error
1%	10,000	27,000
3%	1,000	3,000
10%	100	271

3.6 Operability Check - A low intensity uranium beta source called an operational check source is fastened to the side of the case bottom. This source may be used in conjunction with any of the GM probes connected to the instrument in order to verify operability.

For the Model 491-40, 491-30, and 489-4 beta-gamma probes, the beta shield should be retracted to expose the perforated GM tube guard. One of the square openings in the perforated guard near the center of the GM tube should be placed directly over the 3/8 inch diameter circle on the operational check source, under which the beta source is located. This check must be carried out without the presence of any additional appreciable radiation fields from other sources.

If the count rate obtained on a specific combination of probe and instrument is retained, a periodic repeat of this procedure will give an indication of the constancy of the instrument and probe combination.

The Model 489-35 End Window Probe can be checked in a similar manner by removing the plastic alpha and beta cap from the end of the probe and placing the mica window end of this GM tube on the operational check source directly over the circle identifying the location of the source.

3.7 Use of Carrying Strap - A vinyl, easily decontaminable carrying strap with its attaching strap buckles is optional. The strap anchors are arranged in such a way that the meter is unobstructed when the instrument is carried from the shoulder.

3.8 Detector Probes - Six different GM probe options are available for use on the Model 491. The standard probe, the Model 491-30, provides direct readings on the mR/h scale for ^{137}Cs gamma radiation.

The features of the six probes are shown in the table below. Figures 3 and 4 illustrate the energy response of four of the probes when used with the Model 491.

TABLE II: DETECTOR PROBES

<u>Model No.</u>	<u>Features</u>
491-30....	Standard probe, provides direct readings on ^{137}Cs . 30 mg/cm ² stainless steel wall GM tube. Beta and gamma detection.
491-40....	Decreased sensitivity (approximately 2X for ^{137}Cs). 30 mg/cm ² stainless steel wall GM tube. Beta and gamma detection.
493-50....	Similar to 491-40, but in a plastic beta cage.
489-4.....	Increased sensitivity (approximately 0.4X for ^{137}Cs). 30 mg/cm ² aluminum wall GM tube for good low energy response. Beta and gamma detection.
489-35....	Increased sensitivity (approximately 0.45X for ^{137}Cs). 1.4 to 2.0 mg/cm ² mica end window GM tube for good low energy response. Alpha, beta, and gamma detection.
489-110A..	Thin window pancake GM tube for contamination surveys. Alpha, beta, and gamma detection. Recommend that it be read in cpm only.

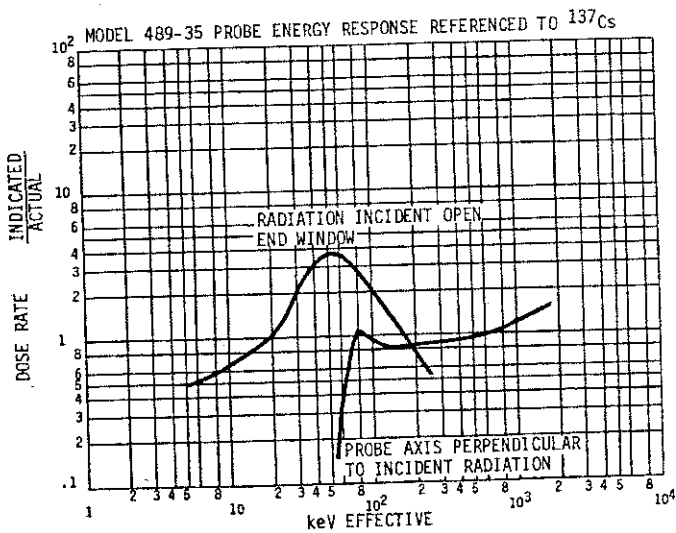
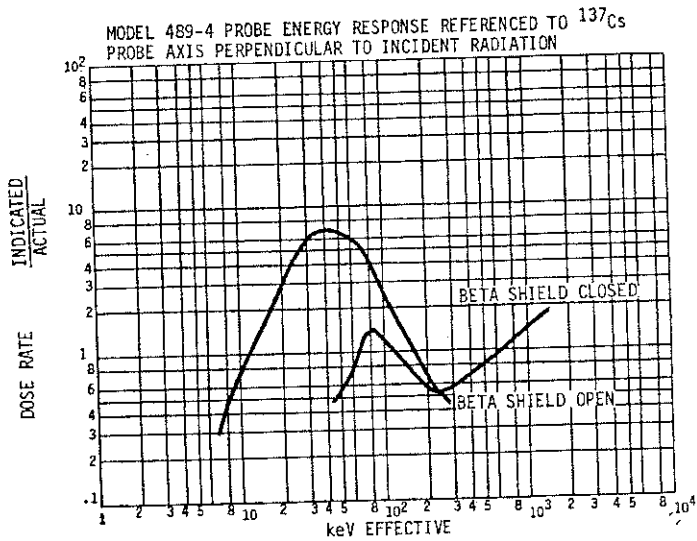

Figure 3. Model 489-4, 489-35 Probe Energy Response Referenced to ^{137}Cs

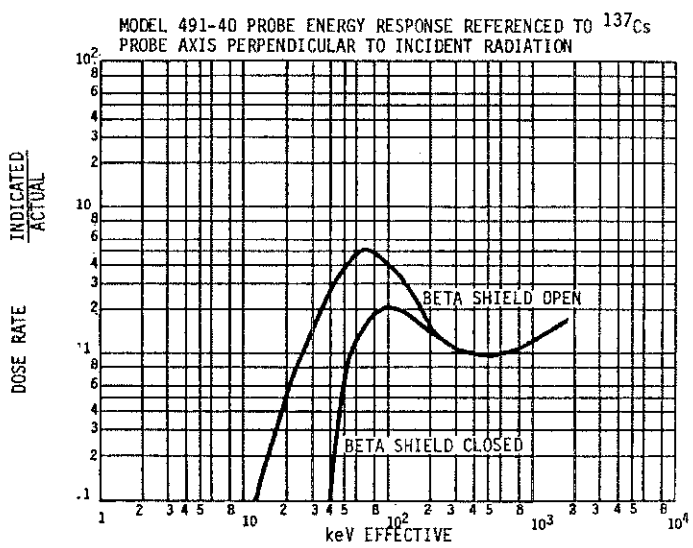
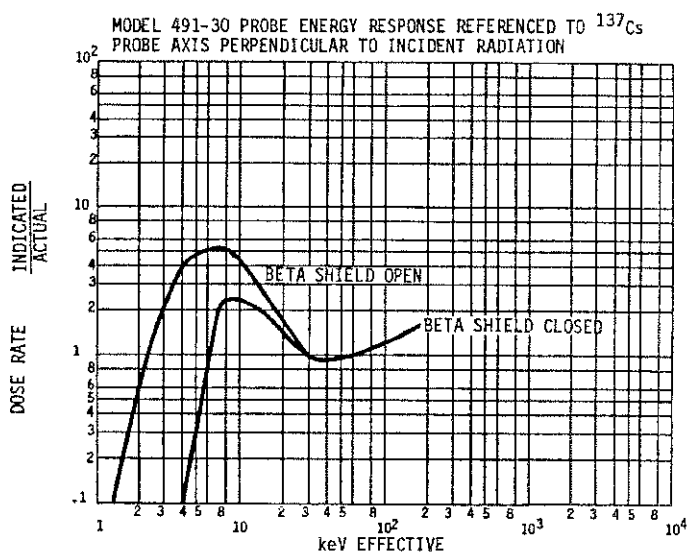

Figure 4. Model 491-30, 491-40 Probe Energy Response Referenced to ^{137}Cs

4 CIRCUIT DESCRIPTION

4.1 Voltage Regulator - The voltage regulator circuit is composed of the series regulator transistor Q7 and the shunt amplifier Q9, Q8. The positive line can be adjusted up +4.1 V using potentiometer R6. Temperature compensation of the instrument is controlled by allowing the power supply voltage to vary in such a manner that the output signal is held constant. The temperature sensing element is thermistor R9.

4.2 High Voltage (+900 V, +/- 20 V) - The high voltage is generated by the blocking oscillator Q6, and utilizes the flyback voltage of the square wave to induce a large peak voltage in the secondary winding. Condenser C7 is used to damp the return flyback voltage so the collector voltage rating of Q6 is not exceeded. The secondary pulse output is rectified by CR1; filtered by R11, R13, R14 and shunt capacitors C6, C5, C4. The output is regulated by V1. Output current capability is 20.

4.3 Signal Circuit - The GM tube signal pulse appearing across R10 is coupled to the single cycle multivibrator (Q2, Q3) via C3 and the input emitter follower circuit Q1. The duration of the multivibrator pulse is determined by the range selector switch S1. The multivibrator pulse turns on Q24 and allows a current flow into the integrating capacitor. The voltage level in the integrating capacitor determines the meter deflection. The nominal pulse duration for a given range is tabulated below:

<u>RANGE mR/h</u>	<u>CPM</u>	<u>PULSE DURATION</u>
0 - 0.1	0 - 150	100,000 microseconds
0 - 0.3	0 - 450	33,000 microseconds
0 - 1	0 - 1,500	10,000 microseconds
0 - 3	0 - 4,500	3,333 microseconds
0 - 10	0 - 15,000	1,000 microseconds
0 - 30	0 - 45,000	333 microseconds
0 - 100	0 - 150,000	100 microseconds

The determining factor on the pulse duration is the resolving time of the GM tube, which is 100 microseconds. This means that the resolution loss at 150,000 cpm is 25%, and, to allow the use of a common scale, this loss must be maintained on all ranges. Therefore, the pulse duration on the 150 cpm (0 - 0.1 mR/h) range must be 1,000 times that used on the 150,000 cpm range (0 - 100 mR/h). The visual result is the tapering of the scale.

4.4 Audio - By connecting an earphone to J1, the signal may be monitored audibly. The signal is derived from the multivibrator, and the output pulse is taken from emitter follower Q5. The phone should have a minimum 1000 ohm impedance.

5 CALIBRATION - Calibration and adjustment of the Model 491 should preferably be done in an ambient temperature of approximately 25°C but any temperature is suitable as long as all the components of the instrument have reached a common temperature.

1. Connect the voltmeter from the collector of Q7 to ground (Figure 5) and adjust R6 for an output voltage of 4.1 V.
2. With the instrument on the 10 mR/h range and an oscilloscope connected to the collector of Q2, adjust R28 for a pulse duration of 1000 microseconds.
3. Place the probe in a 5 to 8 mR/h field and adjust R35 for correct meter reading. All ranges from 0.1 mR/h to 10 mR/h are now calibrated.
4. With the instrument on the 100 mR/h range, place the probe in a field of 50 to 80 mR/h and adjust potentiometer R27 for the correct meter reading.

The calibration may be made using ^{60}Co , ^{226}Ra or ^{137}Cs .

N O T E

The accuracy (mR/h) specifications of the instrument will hold true only for that material on which the instrument has been calibrated.

5.1 Probes - The standard probe for the 491 instrument utilizes a Lionel 112/6833 tube. The assembly is designated as a VICTOREEN Model 491-30 Probe as shown in Figure 6.

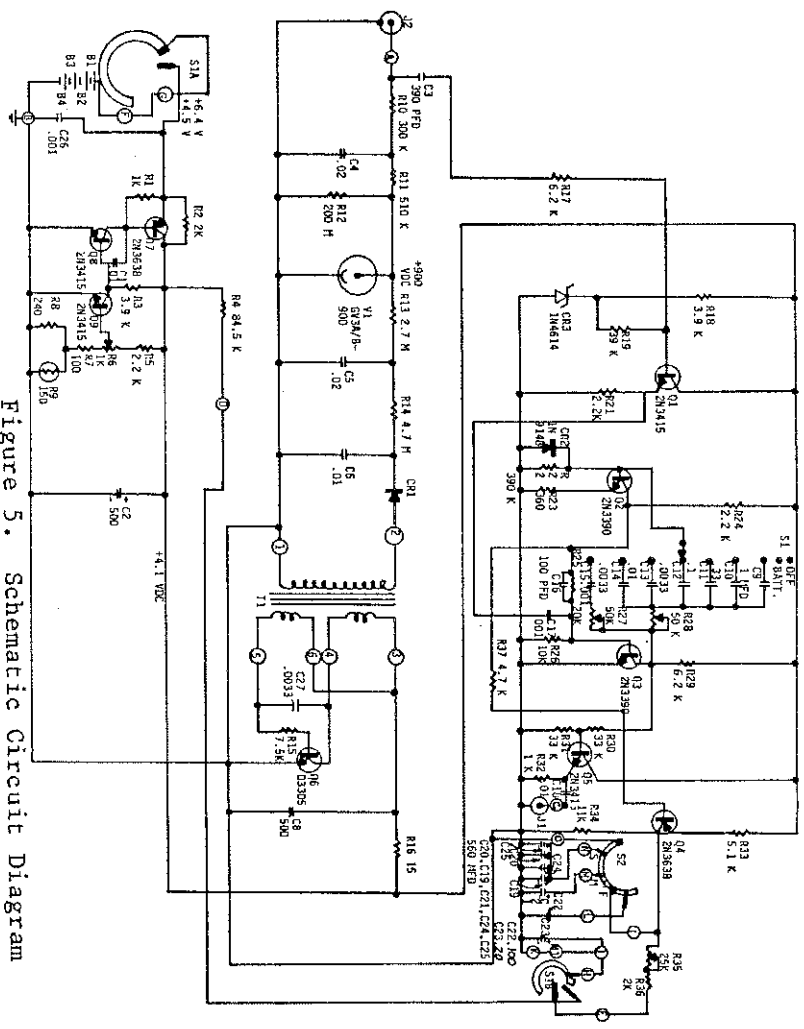

Figure 5. Schematic Circuit Diagram

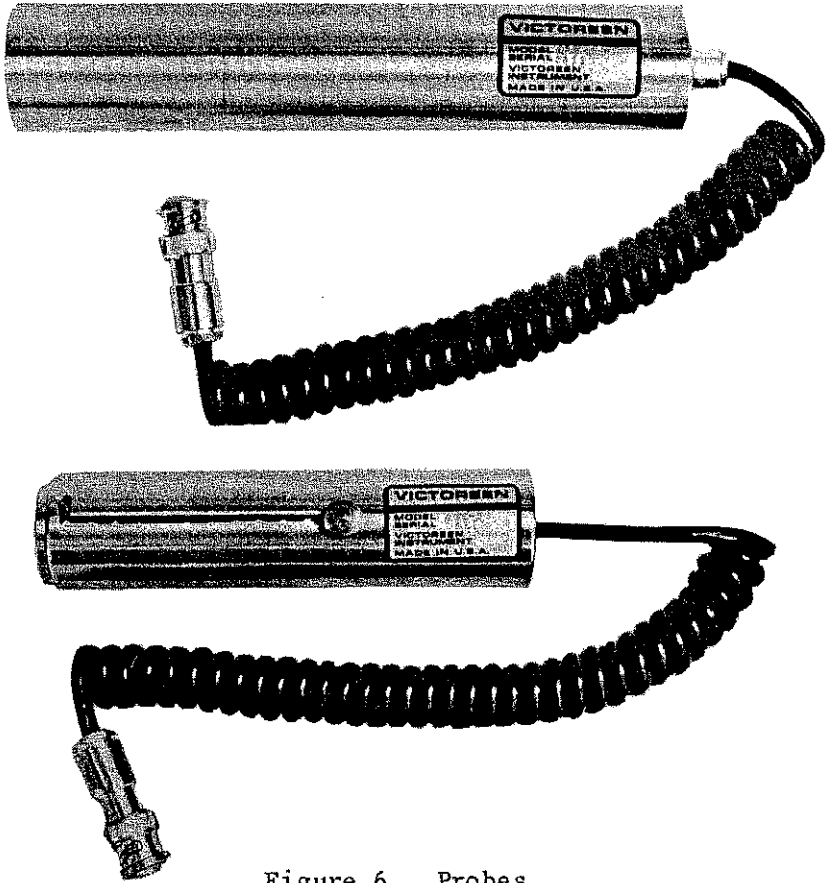

Figure 6. Probes

For alpha or improved beta sensitivity, VICTOREEN Probe 489-35 may be used. This probe utilizes a mica window tube (VG-40) for increased particle sensitivity.

For an approximate reduction in gamma sensitivity of two, the VICTOREEN 491-40 Probe should be used.

For increased beta and gamma sensitivity, the 489-4 Probe may be used. This probe uses a 1B85 Geiger tube.

All of the above probes use GM tubes having resolving time of 100 microseconds, a necessity determined by the taper of the scale. This does not necessarily mean that all probes are usable over the entire span of seven ranges that the instrument provides, as their count rate per mR/h may be considerably above the standard probe. In such cases the 100 mR/h range and possibly the 30 mR/h range may not be used. For utilizing tubes with a lesser count/mR/h ratio, tests should be made to determine the multiplication factor. This multiplication factor may be applied to mR/h readings, but not cpm readings.

Specifications for the above probes are listed in Table III.

TABLE III: PROBES AVAILABLE FOR USE WITH SURVEY METER 491

Probe	Features
491-30	<p>Tube - 112/6833, 900 V, beta and gamma detection Resolving time - 100 microseconds Standard Probe - Read mR/h scale directly for gamma</p>
489-35	<p>Tube - VG-40, 900 V, alpha and beta detection Resolving time - 100 microseconds Usable on all but least sensitive (0-150,000 cpm) range Multiply mR/h reading by 0.45 \pm 10% for gamma</p>
491-40	<p>Tube 6993 - Reduced sensitivity, beta and gamma detection Resolving Time - 100 microseconds Standard Probe - Multiply mR/h reading by 2.2 \pm 10% for gamma</p>
489-4	<p>Tube 1B85 - Increase sensitivity, beta and gamma detection Resolving Time - 100 microseconds Usable on all but least sensitive (0-150,000 cpm) range Multiply mR/h reading by 0.4 \pm 10% for gamma</p>

6 MAINTENANCE

6.1 Preventive Maintenance - The best preventive maintenance that can be recommended is to keep the instrument turned off when it is not in use, to remove the batteries during extended periods of storage, and to be sure that fresh batteries are used.

6.2 Battery Check - Turn function switch to the BAT marking. If the meter needle does not advance to the BAT check zone, battery terminals are corroded and must be cleaned, or the battery is weak and must be replaced. Do not attempt to operate the instrument with weak batteries or batteries with corroded terminals. (See Topic 3.2 for Battery Check and Replacement).

Battery life is about 100 hours with carbon-zinc cells when operated at an average rate of four hours per day. Figure 7 illustrates the voltages appearing at critical points in the instrument. Voltages are taken without an input signal. Waveforms are taken with a Tektronix 561A oscilloscope and provide a better means of analyzing the area of failure.

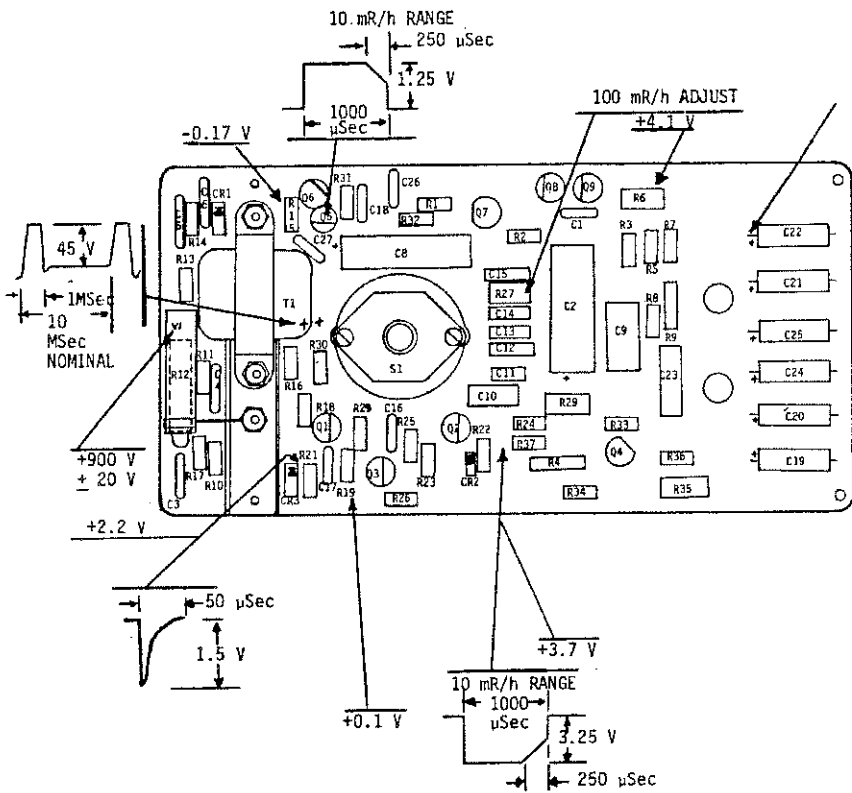

Figure 7. Circuit Board Assembly, Wave Forms, Voltage Check Points and Internal Adjustments

7 REPLACEABLE PARTS

Symbol Desig.	Description	Part No.
B1,B2, B3,B4	Battery, D-cell, 1.5 V	16-4
C1,C18	Capacitor, 0.01 MFD, 25 V	21-663
C2,C8	Capacitor, 500 MFD, 6 V	21-943E
C3	Capacitor, 360 PFD, 2 kV	21-466
C4,C5	Capacitor, 0.02 MFD, 1 kV	21-582
C6	Capacitor, 0.01 MFD, 1.6 kV	21-23
C17,C26	Capacitor, 0.001 MFD, 10%	21-308
C9	Capacitor, 1.0 MFD, 50 V, 2%	21-666
C10	Capacitor, 33 MFD, 100 V, 2%	21-667
C11	Capacitor, 0.1 MFD, 100 V, 2%	21-668
C12	Capacitor, 0.033 MFD, 100 V, 2%	21-669
C13	Capacitor, 0.01 MFD, 100 V, 2%	21-670
C14	Capacitor, 0.0033 MFD, 100 V, 2%	21-671
C15	Capacitor, 0.001 MFD, 100 V, 2%	21-672
C16	Capacitor, 100 PFD, 1 kV	21-45
C19,C20 C21,C24 C25	Capacitor, 560 MFD, 6 V	21-673
C27	Capacitor, 0.0033 MFD, 1 kV	21-427
C22	Capacitor, 100 MFD, 10 V	21-678
C23	Capacitor, 20 MFD, 12 V	21-816
CR1	High Voltage Rectifier	52-114
CR2	Diode, 1N914B	52-219
CR3	Diode: 1N4614	52-348
J1	Phone Jack	700-21
J2	MHV Connector	30-7
M1	Meter	491-8
Q1,Q5		
Q8,Q9	Transistor, 2N3415	23-86
Q2,Q3	Transistor, 2N3390	23-152

7 REPLACEABLE PARTS (Cont'd)

Symbol Desig.	Description	Part No.
Q4,Q7	Transistor, 2N3638	23-61
Q6	Transistor, D33D5	23-120
R1,R32	Resistor, 1 K	185-625
R3,R18	Resistor, 3.9 K	185-225
R4	Resistor, 84.5 K	185-1641
R5,R21 R24	Resistor, 2.2 K	185-656
R6	Potentiometer, 1 K	22-221
R7	Resistor, 100 ohms	185-528
R8	Resistor, 240 ohms	185-566
R9	Thermistor, 150 ohms, 1/4 W, 10%	185-1429
R10	Resistor, 300 K	185-302
R11	Resistor, 510 K	185-3
R12	Resistor, 200 M	185-1640
R13	Resistor, 2.7 M	185-860
R14	Resistor, 4.7 M	185-382
R15	Resistor, 7.5 K	185-231
R16	Resistor, 15 ohms	185-441
R17,R29	Resistor, 6.2 K	185-229
R19	Resistor, 39 K	185-739
R22	Resistor, 390 K	185-392
R23	Resistor, 360 ohms	185-581
R25	Resistor, 20 K	185-135
R26	Resistor, 10 K	185-706
R27,R28	Potentiometer, 50 K	22-249
R30,R31	Resistor, 33 K	185-411
R33	Resistor, 5.1 K	185-224
R34	Resistor, 5.11 K	185-215
R35	Potentiometer, 25 K	22-257
R36,R2	Resistor, 2 K	185-654
R37	Resistor, 4.7 K	185-227
S1,S1A S1B	Switch	491-6
S2	Time Constant Switch	490-9
T1	Transformer	14-76
V1	GM Tube	V3A/B-90

